



**Table of Contents**

28.1 Introduction .....2

    28.1.1 General .....3

    28.1.2 Concrete Spans .....3

    28.1.3 Steel Spans .....3

    28.1.4 Thermal Movement .....3

28.2 Compression Seals .....5

    28.2.1 Description .....5

    28.2.2 Joint Design .....5

    28.2.3 Seal Size .....5

    28.2.4 Installation .....5

    28.2.5 Maintenance .....6

28.3 Strip Seal Expansion Devices .....8

    28.3.1 Description .....8

    28.3.2 Curb and Parapet Sections .....8

    28.3.3 Median and Sidewalk Sections .....8

    28.3.4 Size Selection .....8

        28.3.4.1.1 Example .....9

28.4 Steel Expansion Joints .....11

    28.4.1 Plate Type Expansion Joint .....11

    28.4.2 Finger Type Expansion Joint .....11

28.5 Modular Expansion Devices .....12

    28.5.1 Description .....12

    28.5.2 Size Selection .....13

28.6 Joint Performance .....15



## **28.1 Introduction**

Many structures have joints that must be properly designed and installed to insure their integrity and serviceability. Bridges as well as highway pavements, airstrips, buildings, etc. need joints to take care of expansion and contraction caused by temperature changes. However, bridges expand and contract more than pavement slabs or buildings and have their own special types of expansion devices.

Current practice is to limit the number of bridge expansion joints. This practice results in more movement at each joint. There are so many potential problems associated with joints that fewer joints are recommended practice. Expansion joints are placed on the high end of a bridge if only one joint is placed on the bridge. This is done to prevent the bridge from creeping downhill and to minimize the amount of water passing over the joint.

Open joints generally lead to future maintenance. Water and debris fall through the joint. Water running through an open joint erodes the soil under the structure, stains the bent cap and columns, and leads to corrosion of adjacent girders, diaphragms, and bearings. During freeze-thaw conditions, large icicles may form under the structure or ice may form on the roadway presenting a traffic hazard. Debris acts with water in staining the substructure units and plugs the drainage systems.

In the past, open steel finger type joints were used on long span bridges where large movements encountered. Finger joints were placed in the span near the point of contraflexure and were placed on the structure where they are required structurally. Drains were located to prevent drainage across the joint if feasible. In some areas, they were provided with a drainage trough to collect the water passing through.

Sliding steel plate joints are semi-open joints since water and light debris can pass through. A sealant placed in the joint prevents some water from passing through. It also prevents the accumulation of debris which can keep the joint from moving as it was designed. To date, considerable maintenance has occurred with sealants and neoprene troughs have been added to collect the water at some sites.

Currently finger and sliding plate details are maintained for joint maintenance and retrofitting but are not used for new structures. Watertight expansion devices such as strip seals and modular types are recommended for new structures. Although these expansion joints are not completely watertight; they have been effective in reducing damage to adjacent girders, diaphragms, bearings and substructure units.

The neoprene compression seal is a closed joint which is watertight if it is properly installed and an adequate adhesive is employed. Compression seals are only used for fixed joints. Strip-seals are watertight joints which are used in place of sliding plate joints or finger joints in an attempt to keep water and debris on the bridge deck surface.

Refer to Figure 12.7-1 for placement of expansion devices. The following criteria is used for placement of expansion devices:



### 28.1.1 General

Use watertight expansion joints wherever possible according to the design criteria and of all structure lengths. On skews over 45°, strip seals must be oversized to compensate for racking of the joint. For thermal movements greater than 4 inches modular expansion devices are recommended.

### 28.1.2 Concrete Spans

An expansion device is required if the expansion length of the structure exceeds 300 feet. At this point the geometrics of the structure determine the number of expansion joints required with a maximum expansion length of 400 feet.

As an example, consider a prestressed girder structure 700 feet long on flexible piers and 0° skew. Considering the two piers near the center of the span as fixed, the structure can expand toward each abutment with maximum expansion lengths less than 400 feet. A 400 series model strip seal expansion joint at each abutment is adequate for this structure.

### 28.1.3 Steel Spans

Watertight joints are required on all painted and unpainted steel structures to control staining of the substructure units due to corrosion of the steel girders, diaphragms, and bearings.

See Figure 12.7-1 to determine the appropriate abutment type and, hence, whether expansion devices are required. The geometry of the structure determines the number of expansion devices required and the amount of movement at each device. Some factors to consider are temperature expansion with high skew angles may cause "racking" of the structure; higher abutments have more uncertainty to movement due to backfill pressure; and curved girders add torsional and shear forces.

Long span structures on tall flexible piers may have much longer expansion lengths than short span structures on short rigid piers. The longer spans have much less resistance to horizontal temperature movement caused by bearing friction and pier rigidity. These types of structures are designed for joint movements of 4 inches or greater using modular expansion devices.

### 28.1.4 Thermal Movement

The maximum thermal movement required at expansion joints is based on the following table:



Structure Type	Temperature Range	Thermal Coefficient
Steel:	-30 to 120°F	0.0000065/F
Concrete:	+5 to 85°F	0.0000060/F
*Prestressed Girder:	+5 to 85°F	0.0000060/F

**Table 28.1-1**  
Thermal Movement

\* For Prestressed girders add shrinkage due to creep of .0003 ft/ft. This value should be used in setting the joint opening as the joint opening will continue to widen over time.

The expansion length is measured along the centerline of the bridge and the length is normal to the joint opening for structures with a zero skew. The designer should provide adequately sized joints (i.e. round up in size if between two joint sizes or use additional joints or a different type of joint).

The annual mean temperature for Wisconsin is 45 °F. For the setting of strip seal expansion devices, see Standard for Strip Seal Expansion Joint Details for the joint opening when the expansion length is less than or equal to 230 feet. When the expansion length is greater than 230 feet show a temperature table with the joint openings from 5°F to 85°F in 10°F increments.

Note that the neutral point for temperature movement is not always located at the fixed pier. See Chapter 13 – Piers for an explanation of how to calculate the neutral point.

**28.2 Compression Seals**

28.2.1 Description

This is a preformed, compartmented, elastomeric polychloroprene (neoprene) device. It is used sparingly on fixed joints provided there is little or no movement of the joint as the seals tend to leak over time.

28.2.2 Joint Design

Currently, most applications are for bridge rehabilitation where the seal is installed into the concrete deck without armor.

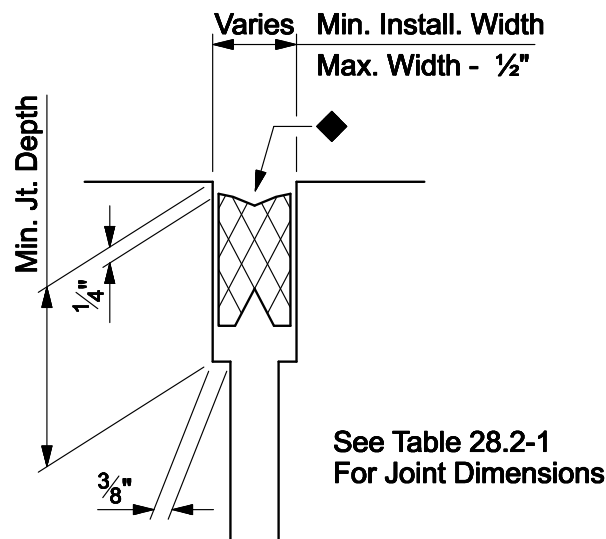

◆ Manufacturer Must Label Top Of Seal

**Figure 28.2-1**  
Joint Design

Manufacturer must label top of seal.

28.2.3 Seal Size

The width of the compression seal to be used in a given joint opening is computed by adding the as-constructed joint width plus a small width safety factor. For best results oversize the seal by a minimum of 1/2 inch. See [Table 28.2-1](#) for approximate dimensions.

28.2.4 Installation

Ease of installation is achieved using a lubricant-adhesive which as the name implies acts initially as a lubricant then cures out to form an adhesive membrane between the contact



faces of the angle and seal. This membrane together with the compressive action of the seal is designed to provide a waterproof joint interface.

Compression seals are only used for fixed joints. The following information is a guide for the installation of neoprene compressive seals:

1. Thorough cleaning of joint faces is essential. Forced air or manual dusting handles most cases; use a solvent on oily areas.
2. Require application of the manufacturer's lubricant-adhesive to the sides of the neoprene seal as well as the joint faces. An adequate coating of the lubricant-adhesive is helpful in installation.
3. Proper installation tools consist of hand or machine tools that compress and eject the seal or weighted rollers that squeeze it in place. Screwdrivers, pry bars or other sharp ended tools which may puncture the seal are not allowed.
4. Stretching in excess of 5% is not permitted.
5. It is imperative that the seal be installed below the pavement surface. The minimum depth recess to top of seal is  $\frac{1}{4}$  inch.
6. Prior to shipping, all compression seals are to be labeled TOP SIDE by the manufacturers. Field installation reports indicate difficulty in determining TOP SIDE for some types of seals. Also, the seal cross-section is not shown on a shop drawing unless the joint is armored.

### 28.2.5 Maintenance

Manual removal of incompressible materials which tend to collect within the joint opening is desirable. However, in most cases this is not necessary since the tire forces the material against the elastic neoprene seal which rebounds causing the material to bounce up and out of the seal.

It is essential to the operation of the seal that no form of hot or cold joint filler be placed over the top of the seal. This includes resurfacing mats or overlays. The reasons are as follows:

1. Hot fillers may either melt the seal or seriously affect the elastomeric properties for future performance.
2. The filler acts as a constant media of transmitting undue vertical tire forces to the compression seal which may break the interface bond.



SEAL WIDTH	SEAL HEIGHT	MIN. JOINT WIDTH	MAX. JOINT WIDTH	*MIN. INSTALL. WIDTH	MIN. JOINT DEPTH
2	2 ±	1 ±	1 ¾ ±	1 ¼ ±	2 ⅞ ±
2 ¼	2 ½ ±	1 ±	2 ±	1 ⅜ ±	3 ⅛ ±
2 ½	2 ¾ ±	1 ¼ ±	2 ¼ ±	1 ⅝ ±	3 ⅝ ±
3	3 ⅜ ±	1 ⅜ ±	2 ½ ±	1 ¾ ±	4 ¼ ±
3 ½	3 ½ ±	1 ½ ±	3 ±	2 ⅞ ±	4 ¾ ±
4	4 ½ ±	1 ¾ ±	3 ½ ±	2 ⅝ ±	5 ½ ±

**Table 28.2-1**  
Approximate Compression Seal Dimensions

\* This is the minimum practical limit as suggested by the seal manufacturer.



### **28.3 Strip Seal Expansion Devices**

#### **28.3.1 Description**

Strip seal expansion devices are molded neoprene glands inserted and mechanically locked between armored interfaces of extruded steel sections. The name "Strip Seal" is derived from the strip profile of the neoprene seal. During structure movements a preformed central hinge enables the strip seal profile to fold between the seal extrusions. Strip seal design details are given on the Standards for Strip Seal Expansion Joint Details and Strip Seal Cover Plate Details.

Ease of installation is attained by applying a lubricant-adhesive to the steel extrusions; which as the name implies acts initially as a lubricant; then cures to form an adhesive membrane between contact surfaces of the extrusions and neoprene gland. The neoprene glands are generally inserted in the field by using a tire-iron type tool. A minimum transverse roadway surface opening between the extrusions of 1 ½ inches or greater will facilitate the field installation of the neoprene gland. When extra size or travel capacity is available, joint openings can be increased to facilitate gland installation keeping the maximum transverse roadway joint opening at 4 inches for new construction. Greater openings may be used on maintenance projects only.

The strip seal is readily adaptable to changes in interfacial elevations as well as longitudinal skew deformations. The neoprene gland is installed as one continuous length on any given joint application. Additional considerations are given to the "racking" movement on the neoprene gland as the structure skew angle increases.

#### **28.3.2 Curb and Parapet Sections**

The strip seal is curved up into the curb or safety parapet with cover plates. The details are shown on Standard for Strip Seal Cover Plate Details. The resulting recess between the parapet and joint requires cover plates for maintenance considerations.

#### **28.3.3 Median and Sidewalk Sections**

Median cover plates are not required if the joint is placed at the median surface, otherwise they are required. All sidewalk joints must have cover plates as shown on the standard details.

#### **28.3.4 Size Selection**

The first consideration in strip seal size selection is the effective expansion length for the given joint location. [Table 28.1-1](#) is established in accordance with AASHTO Specifications by employing a cold climate temperature range given in [28.1.4](#) for determining the maximum span lengths for the joint movement limits. The span length was decreased for prestressed girder structures to further accommodate movements due to concrete creep and shrinkage. The "Maximum Expansion Length" for a given joint size and structure type is shown in [Table 28.3-1](#)

On new structures and deck replacements, provide details for strip seal models having a minimum size of 4 inches. If the skew angle exceeds 30 degrees, limit the actual racking displacement to 60 percent of the seal's rated capacity or select the next larger size neoprene gland model to reduce stresses caused by racking. For skew angles greater than 45 degrees, limit the actual racking movement to 50 percent of the seal's rated capacity. Some manufacturers provide a 5 inch gland which makes an excellent alternate on installations sized for 4 inches of movement on a high skewed structure. The maximum allowable opening perpendicular to the center line of the joint is 4 inches on all structures.

After selecting the proper strip seal model, refer to [Table 28.3-1](#) for the joint opening at the mean shaded underside of deck temperature of 45°F. The dimensions are given normal to the joint opening in the roadway measured between the inside edges of the extrusion on the top sides. Refer to the Strip Seal design example for additional considerations regarding skew angle and joint installation. A minimum transverse roadway joint opening of 1 ½ inches or greater is recommended measured from between the top inside extrusion edges to facilitate the neoprene gland installation and/or replacement.

Performance evaluations of strip seal joints in-service indicate that the neoprene glands are not always installed properly. In some cases, both "ears" of the neoprene lug have not been inserted into the steel extrusion. In other cases, the gland has been installed upside down. As a result, manufacturers are requested to label "Topside" on the neoprene glands prior to shipping.

**28.3.4.1.1 Example**

Strip Seal Application, minimum size is 4 inch size. Given: Prestressed concrete girder structure having 350 feet of expansion length with a 33 degree skew angle.

From [Table 28.3-1](#), under Prest., select the minimum size 4 inch size and check the racking displacement in accordance with [28.3.4](#).

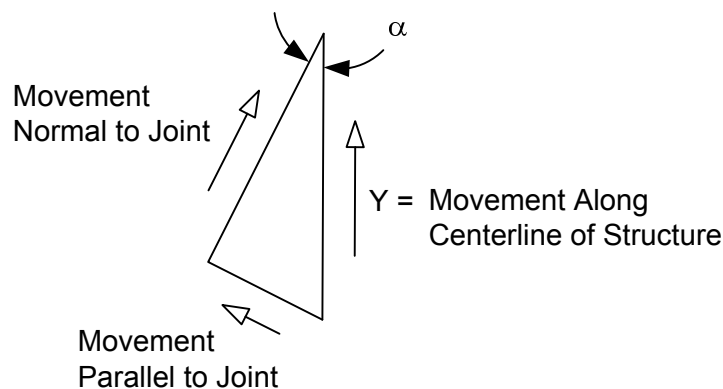

**Figure 28.3-1**  
Racking Displacement

$$Y = (350')(12'') \cdot (6 \times 10^{-6})(80) + (350')(12'')(0.0003) = 2'' + 1.26'' = 3.26''$$



$$Y(\text{normal}) = Y(\cos \alpha) = 3.26 \cos 33^\circ = 2.73''$$

$$Y(\text{parallel}) = Y(\sin \alpha) = 3.26 \sin 33^\circ = 1.78''$$

In this case parallel racking as a percentage of joint capacity is 44.5% (< 60%) of the 4 inch model capacity.

Refer to [Table 28.3-1](#) for joint opening at 45°F which is 2 1/4 inches. The opening size should be reduced by 1 1/4 inches to account for future creep and shrinkage, but maintain 1 1/2 inch minimum opening. Show the Strip Seal Size on the plans. Approved Joint Manufacturers are shown in the STSP's.

Size	Inch Travel	Max. Expansion Lengths (feet)			Jt. Opening @ 45°F (inch)
		Conc	Prest	Steel	
4-Inch	± 2	615	380	300	2 1/4
5-Inch	Recommended for expansion movement requirements ranging from 3" to 4" on skews greater than 30 degrees. Use the same criteria as with the 4-inch models.				
The joint opening at 45°F is given at mean shaded underside deck temperature normal to the joint for zero degree skew of structure. Show joint openings from 5°F to 85°F in 10°F increments if the expansion length exceeds 230 feet. For prestressed girders the joint opening should be reduced by the amount calculated for future creep and shrinkage. A minimum opening of 1 1/2 inches is required for setting.					

**Table 28.3-1**  
Expansion Joint Openings



## **28.4 Steel Expansion Joints**

With the availability of modular watertight joints having 3 inch increments of expansion capacity and greater, steel expansion devices are becoming less attractive. Positive protection against expansion joint leakage is required to prevent deterioration of bridge bearings and supporting substructure units. Steel expansion joints can be made watertight by using neoprene troughs. Past experience indicates that maintenance is required on a routine basis to keep the drain troughs free of debris. However, steel expansion devices with neoprene troughs are occasionally detailed on designated projects.

### **28.4.1 Plate Type Expansion Joint**

The plate type expansion joint is limited to structures having relatively small thermal movements. The plate type expansion joint is generally limited to movements less than 2 ½ inches. When this joint is inspected before installation, examine the joint for warpage with the plates lying together loose and not bolted. When the plates are bolted, it is difficult to detect plate warpage. There are maintenance problems such as deterioration of the joint fillers and sliding plates resulting in joint leakage.

### **28.4.2 Finger Type Expansion Joint**

The finger type expansion joint is recommended for structures requiring thermal movements greater than 4 inches. The plate girder finger joint details are shown in Chapter 40.

Expansion joint supports are detailed under the roadway portion of the deck at each girder. When the exterior girder is positioned under a curb section, a support is detailed off the end diaphragm approximately 20 inches from the face of the curb. If the girder spacing or magnitude of the skew angle creates a length of expansion joint greater than 12 feet between adjacent girders; an intermediate support is placed off each end diaphragm at its midspan.

An optional field welded transverse joint is permitted on all steel expansion joints which are detailed over 34 feet in length. The joint location or weld details are not shown on the bridge plans; actual fabrication details are approved on the shop drawings.

Prior to the deck pour, a minimum blockout of 5 feet on each side of the joint is required for finger type expansion joints. This procedure eliminates rotation of the pre-set expansion joint during the deck pour. The finger joint is set and the blocked-out section is poured after the deck pour.



## **28.5 Modular Expansion Devices**

### 28.5.1 Description

Modular expansion devices consist of molded elastomeric seals which are mechanically locked between steel separation beams. The name "Modular" is used due to the configuration which incorporates a series of standard units. Each unit can accommodate 3 inches of movement; up to 30 inches of movement normal to the joint can be provided. The separation beams are supported by individual support beams; welding provides a permanent contact. The support beam is held down by its extremities at the bearings and is seated within the support box. The support boxes are to be constructed with a minimum steel plate thickness of ½ inch.

The steel separation beams are spaced uniformly via a system of springs that counter the forces exerted on the seals. The springs are arranged such that they will be compressed when the joint is open and the seals are extended. They will relax as the elastomeric seals go into compression due to a rising temperature. Separation beams shall be designed for vertical load of AASHTO HS20 Live Loading plus a minimum of 30 percent for impact and a horizontal load of 50% of vertical load. Specifications should include fatigue testing of weld details for separation beam to support beam connections.

The joint should be designed for 100,000,000 fatigue cycles. All joints should be tested and certified that they meet the loading requirements. Modular expansion devices are prefabricated as a single unit and transported to the site. Generally the anticipated joint opening is preset during fabrication and held in place with threaded rods. If the field temperature varies by more than 10°F from the preset temperature; the joint opening is reset just prior to the closure pour. Refer to [Figure 28.5-1](#) showing the strip-seal type neoprene gland element. The elastomeric neoprene box or strip seals are installed as one continuous length on any given joint application. In all cases, the modular expansion device is carried through the curb line without any change in direction and turned up at their extremities. Cover plates are detailed to cover and transition the gap on sidewalks and other areas as needed.

Manufacturers recommend sizing the modular expansion device for the calculated movement perpendicular to the joint opening. Also, this recommendation is made for skewed structures. However, consideration should be given to selecting the next higher 3 inch capacity joint where skews are involved. This cost is nominal in comparison to the benefits gained from reducing the racking movement and stress in the seal parallel to the joint opening.

Research indicates that continuous modular expansion devices eliminate possible points of leakage by not having surfaces that have to be sealed. The higher installation costs of modular systems are offset by their greater capacity, improve performance, and reduced future maintenance costs.

Some construction details are recommended for long term performance of modular expansion devices. Minimum thickness of the separation beams, anchor beams and plates holding the equalizers is ¾ inch. Full penetration welds should be used between the separation beams and individual support beams. All joined surfaces should be welded, this

applies mainly to the support boxes. Use maximum spacing of 8 feet to support the device during deck construction.

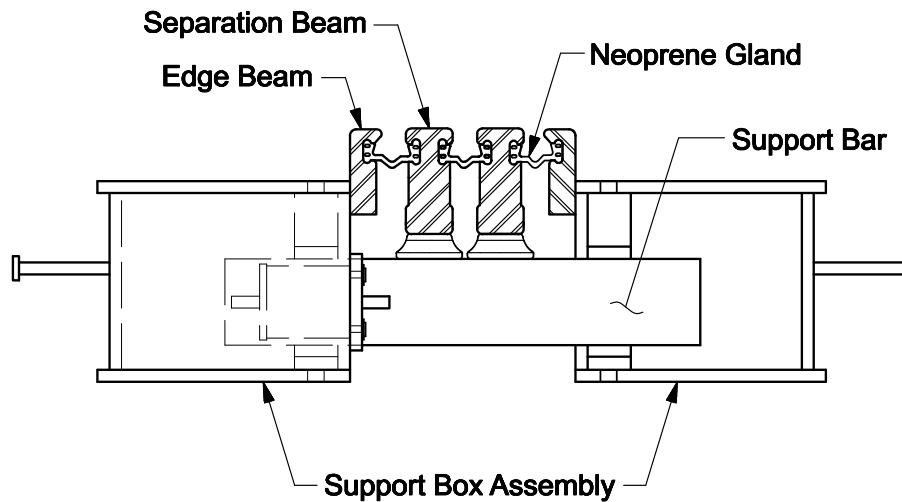

**Figure 28.5-1**  
Modular Expansion Device

### 28.5.2 Size Selection

The first consideration is the effective span length for computing total thermal movement at the given joint location. [Table 28.5-1](#) is established in accordance with AASHTO Specifications for a cold climate temperature range of  $-30^{\circ}$  to  $120^{\circ}\text{F}$ . for steel girder structures. For preliminary design, maximum span lengths in [Table 28.5-1](#) may be increased by 25 percent for multi-span prestressed girder structures. A more exact analysis shall be made for prestressed girder structures taking into account the shortening due to creep and shrinkage of the concrete. The maximum expansion length, block out depths, and width requirements for a given joint size vary by manufacturer as the transverse separation beams vary in top flange width. Final construction details are to be as shown on approved shop drawings.

As an example, the size selections for a steel girder structure having an expansion length of 720 feet and a zero degree skew are the 3 cell models. However, the next size joint should be considered as it is desirable to allow 1 inch and preferably 2 inches extra movement for construction discrepancies. The strip-seal as an alternate sealing element has the advantage of being easier to install, allows a lower height of joint, and offers excellent tear resistance when reinforced.

After selecting the proper modular expansion device size, refer to [Table 28.5-1](#) for the required clear opening between all flange tips at the mean temperature of  $45^{\circ}\text{F}$ . ( $Z = 1+2+3$ ) Manufacturers of modular expansion joints recommend setting the joint opening just prior to completing the concrete pour.

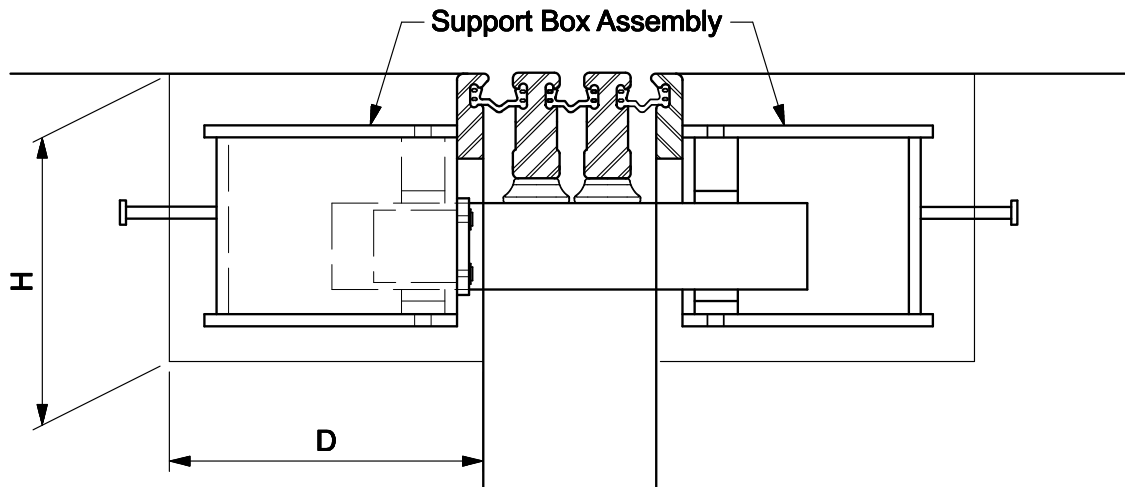

**Figure 28.5-2**  
Modular Expansion Device Dimensions

Number of Cells	Max. Thermal Movement (inch)	Maximum Expansion Lengths (1) (feet)	Expansion Device Settings @ 45°F (2) (inch) Z	Standard Dimensions (2) (inch)	
				H	D
2	6	520	3	17 ±	18 ±
3	9	780	4 ½	17 ±	21 ±
4	12	1040	6	18 ±	25 ±

**Table 28.5-1**  
Joint Clear Opening

1. Maximum expansion range is based on steel girder structures in cold climate temperatures; -30 to 120°F.
2. The joint opening shown as Z for 45°F is taken at mean shaded underside of deck temperature normal to the joint for zero degree skew of structure. Separation beam flange widths vary between manufacturers and these values are given for total opening, actual dimensions shall be verified from manufacturer's standard details or shop drawings. See [Figure 28.5-2](#)

Coping of wide flanged prestressed concrete girders may be necessary to facilitate placement of the support boxes.



**28.6 Joint Performance**

Currently the approved modular expansion devices with continuous neoprene seals and individual bearing support bars have performed well. From the maintenance standpoint, they are preferred over steel finger joints with troughs that require periodic cleaning. Galvanizing modular expansion joints is required due to the number of steel components subjected to chlorides and potential for corrosion. Strip seal joints require galvanizing too.

Joint cleaning and inspection/repair of the neoprene glands is imperative to insure long-term joint performance.



This page intentionally left blank.