

**PART LONGIT. SECTION**

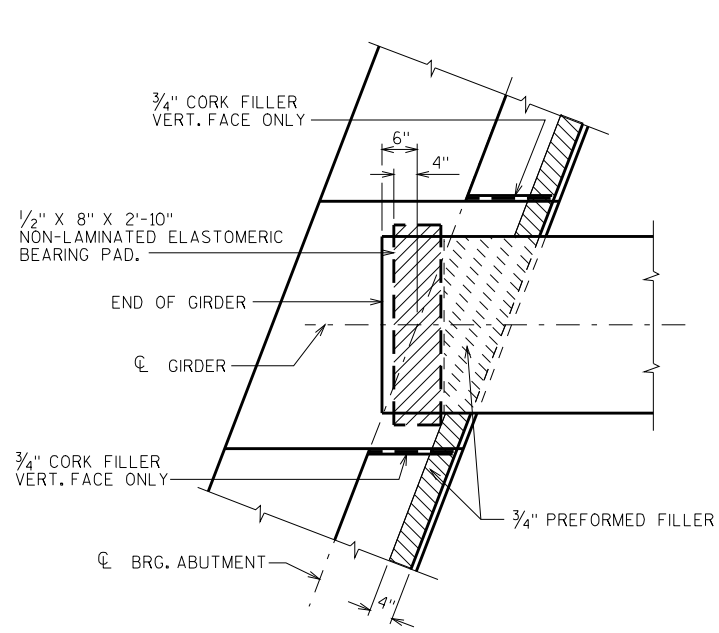

**BEARING PAD DETAIL**

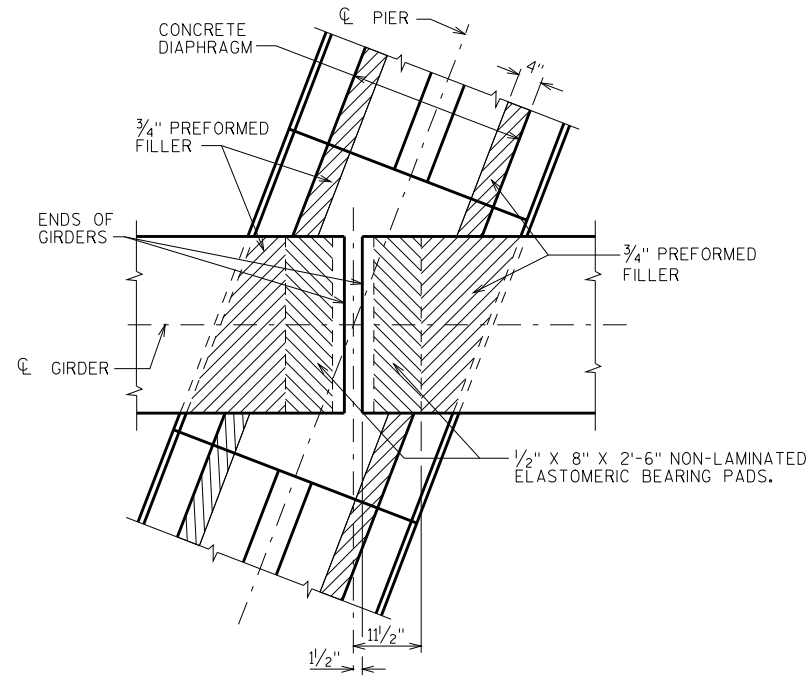

15  
118  
1 2 3 4

8

NO.	DATE	REVISION	BY
STATE OF WISCONSIN DEPARTMENT OF TRANSPORTATION STRUCTURES DESIGN SECTION			
<b>STRUCTURE</b>			
DRAWN BY		PLANS CK'D.	
<b>SUPERSTRUCTURE DETAILS</b>			SHEET