

GIRDER NOTES

TOP OF GIRDER TO BE ROUGH FLOATED AND BROOMED TRANSVERSELY, EXCEPT THE OUTSIDE 2" OF GIRDER, WHICH SHALL BE TROWEL FINISHED.

THE GIRDERS SHALL BE PROVIDED WITH A SUITABLE LIFTING DEVICE FOR HANDLING AND ERECTING THE GIRDERS.

PRESTRESSING STRANDS SHALL BE - 7 WIRE LOW-RELAXATION STRANDS WITH AN ULTIMATE STRENGTH OF 270,000 PSI AND SHALL BE FLUSH WITH THE ENDS OF THE GIRDER.

BEND EACH END OF #4 STIRRUPS 4 1/2" AND #6 STIRRUPS 6 1/2".

FOR DIAPHRAGM INSERT & CONNECTION DETAILS SEE "STEEL DIAPHRAGM" SHEET.

ALL GIRDERS SHALL BE CAST FULL LENGTH AS SHOWN.

SPACING SHOWN FOR #4 STIRRUPS IS FOR GRADE 60 REINFORCEMENT, IF THE FABRICATOR WANTS TO BUILD A BAR STEEL CAGE BY WELDING LONGITUDINAL REINFORCEMENT TO THE #4 STIRRUPS, 2 OPTIONS ARE AVAILABLE:

1. USE ASTM A706, GRADE 60 REINFORCEMENT AND THE STIRRUP SPACING AS SHOWN ON THE PLANS.
2. USE ASTM A615, GRADE 40 REINFORCEMENT AND A MODIFIED STIRRUP SPACING SUBMITTED TO AND APPROVED BY THE STRUCTURES DEVELOPMENT SECTION.

AN ALTERNATE EQUIVALENT OF WELDED WIRE FABRIC (WWF) MAY BE SUBSTITUTED FOR THE STIRRUP REINFORCEMENT SHOWN, UPON APPROVAL OF THE STRUCTURES DEVELOPMENT SECTION.

WELDED WIRE FABRIC SHALL CONFORM TO THE REQUIREMENTS OF ASTM A497.

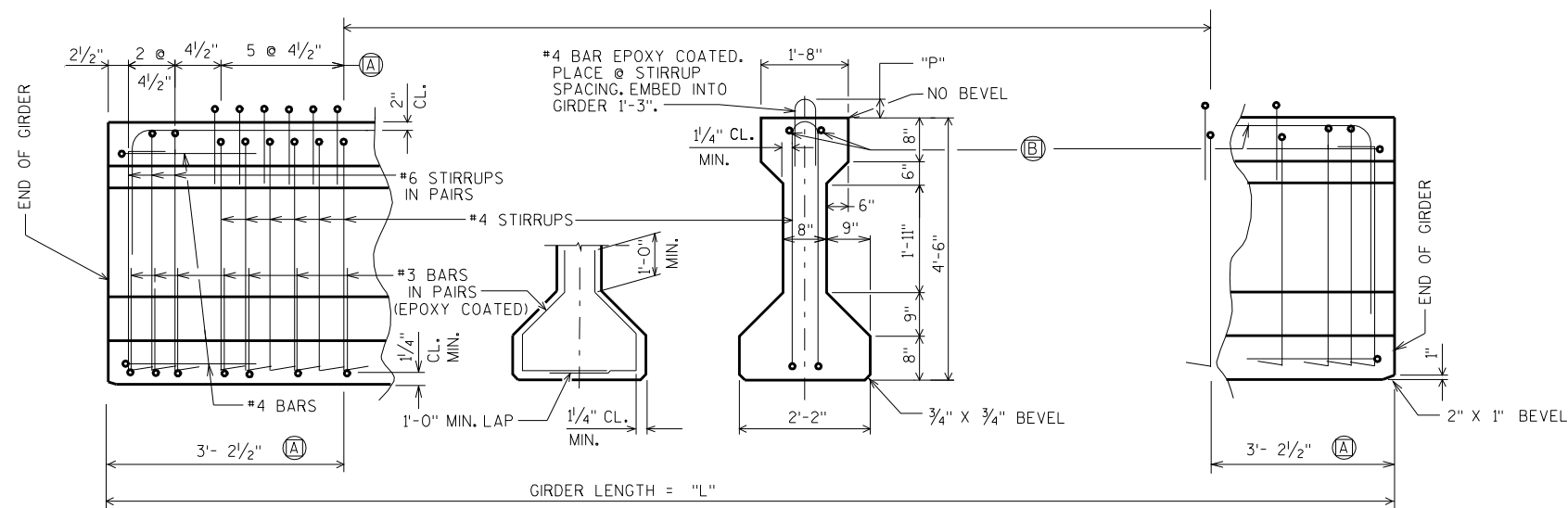

SIDE VIEW & TYP. SECTION IN SPAN

(A) DETAIL TYP. AT EACH END
(B) 2-BARS BEND DOWN 16 BAR DIA. AT ENDS

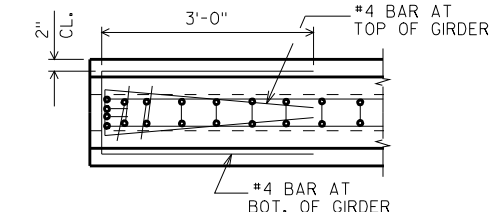

TOP VIEW OF GIRDER ENDS

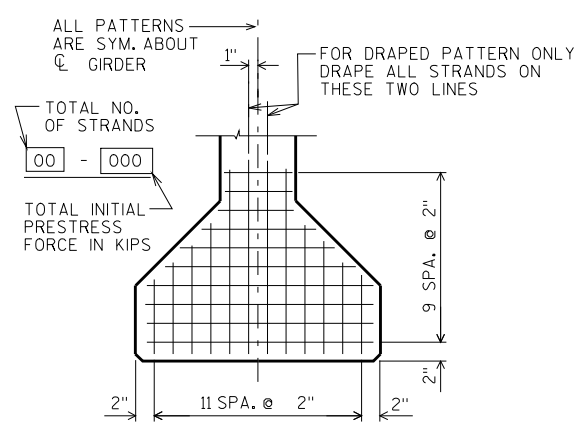

TYP. STRAND PATTERN

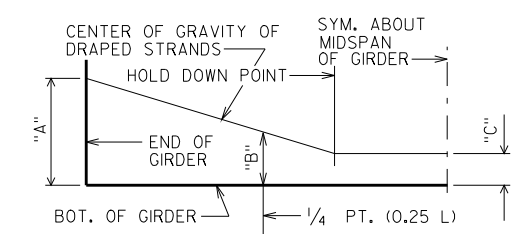

DRAPED STRAND PROFILE

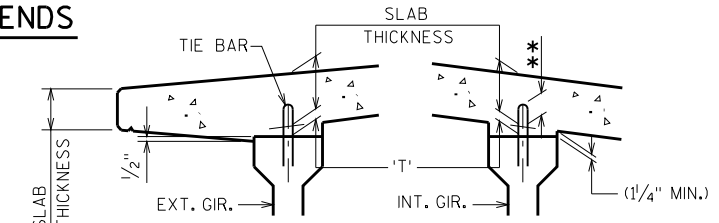

SLAB HAUNCH DETAIL

IF 1/4" MINIMUM HAUNCH HEIGHT AT EDGE OF GIRDER CANNOT BE MAINTAINED, THE GRADE LINE MAY BE REVISED BY THE ENGINEER AT THE OPTION OF THE CONTRACTOR. THE PLAN SLAB THICKNESS SHALL BE HELD. NOTIFY THE STRUCTURES SECTION IF THE GRADE LINE IS RAISED FROM THE PLAN PROFILE BY MORE THAN 1/2" OR.

** IF 3" MINIMUM DECK EMBEDMENT OF TIE BAR CANNOT BE OBTAINED.

TO DETERMINE 'T', ELEV. OF TOP OF GIR'S. AT CL OF SUBSTRUCTURE UNITS & AT 1/10 POINTS OF EACH SPAN SHALL BE TAKEN. THEN FOLLOW THIS PROCESS:

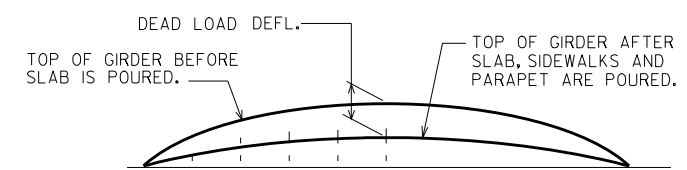

DEAD LOAD DEFLECTION DIAGRAM

TOP OF DECK ELEV. AT FINAL GRADE
- TOP OF GIRDER ELEVATION
+ DEAD LOAD DEFLECTION
- SLAB THICKNESS
= HAUNCH HEIGHT 'T'

NOTE: AN AVERAGE HAUNCH ('T') OF _____ WAS USED IN THE QUANTITY "CONCRETE MASONRY BRIDGES".

* MINIMUM CYLINDER STRENGTH OF CONCRETE @ TIME OF TRANSFER OF PRESTRESS FORCE.

SPAN	GIRDER LENGTH "L"	DEAD LOAD DEF. (IN.)					CONC. STRGTH. f'c (P.S.I.)	"P"	DIA. OF STRAND (IN.)	DRAPED PATTERN (IN.)				UNDRAPED PATTERN					
		1/10	2/10	3/10	4/10	5/10				TOTAL NO. OF STRANDS	f'ci (P.S.I.) *	"A"	"B" MIN.	"B" MAX.	"C"	TOTAL NO. OF STRANDS	f'ci (P.S.I.) *		

NO.	DATE	REVISION	BY
STATE OF WISCONSIN DEPARTMENT OF TRANSPORTATION STRUCTURES DESIGN SECTION			
STRUCTURE			
DRAWN BY		PLANS CK'D.	
54" PRESTRESSED GIRDER DETAILS			SHEET

8

DRAPED PATTERN

UNDRAPED PATTERN

8

SCALE =

LV = 123