

**STANDARD ARRANGEMENTS TO RAISE CENTER OF GRAVITY TO AVOID DRAPING OF STRANDS**

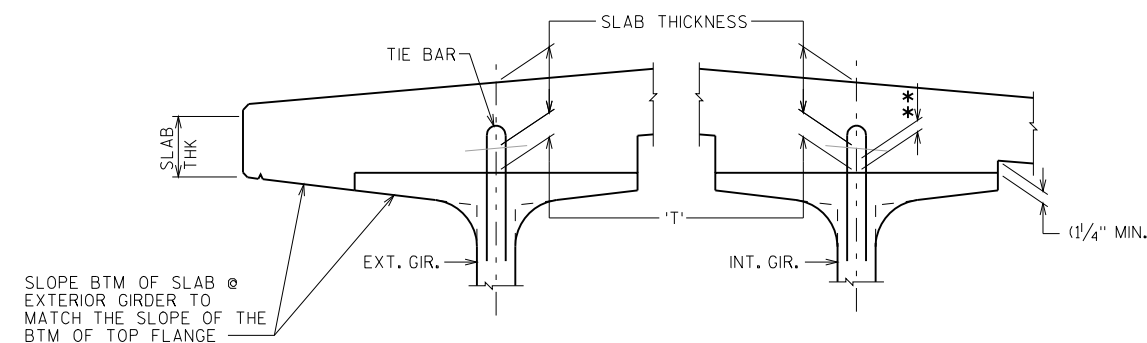

**SLAB HAUNCH DETAIL**

IF 1/4" MINIMUM HAUNCH HEIGHT AT EDGE OF GIRDER CANNOT BE MAINTAINED, THE GRADE LINE MAY BE REVISED BY THE ENGINEER AT THE OPTION OF THE CONTRACTOR. THE PLAN SLAB THICKNESS SHALL BE HELD. NOTIFY THE STRUCTURES SECTION IF THE GRADE LINE IS RAISED FROM THE PLAN PROFILE BY MORE THAN 1/2" OR.  
 \*\* IF 3" MINIMUM DECK EMBEDMENT OF TIE BAR CANNOT BE OBTAINED.

TO DETERMINE 'T', ELEV. OF TOP OF GIR'S. AT  $\bar{C}$  OF SUBSTRUCTURE UNITS & AT 1/10 POINTS OF EACH SPAN SHALL BE TAKEN. THEN FOLLOW THIS PROCESS:

$$\begin{aligned} & \text{TOP OF DECK ELEV. AT FINAL GRADE} \\ & - \text{TOP OF GIRDER ELEVATION} \\ & + \text{DEAD LOAD DEFLECTION} \\ & - \text{SLAB THICKNESS} \\ & = \text{HAUNCH HEIGHT 'T'} \end{aligned}$$

NOTE: AN AVERAGE HAUNCH ('T') OF \_\_\_\_\_ WAS USED IN THE QUANTITY "CONCRETE MASONRY BRIDGES".

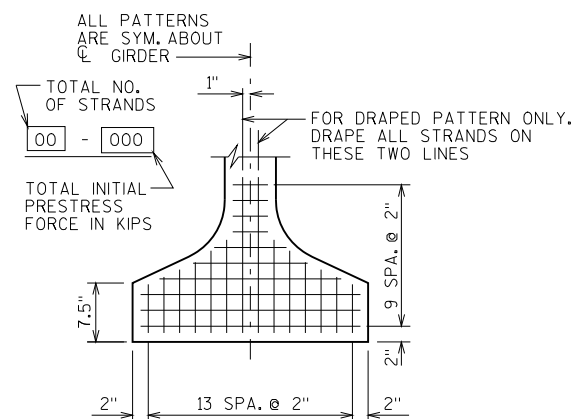

**TYP. STRAND PATTERN**

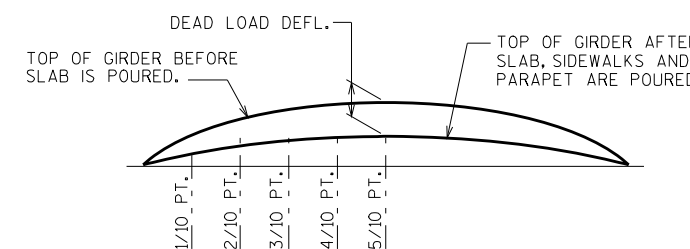

**DEAD LOAD DEFLECTION DIAGRAM**

**ARRANGEMENT AT  $\bar{C}$  SPAN - FOR GIRDERS WITH DRAPED STRANDS**

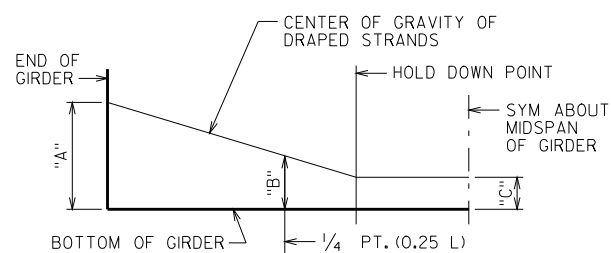

**DRAPED STRAND PROFILE**

THE THEORETICAL INITIAL CAMBER VALUE AT THE TIME OF STRAND RELEASE AT MIDSPAN

SPAN	CAMBER (IN.)

THESE VALUES ARE NOT TO BE USED IN DETERMINING 'T'. USE ACTUAL GIRDER SHOTS. THESE VALUES ARE FOR INFORMATIONAL PURPOSES ONLY.

NO.	DATE	REVISION	BY

STATE OF WISCONSIN  
 DEPARTMENT OF TRANSPORTATION  
 STRUCTURES DESIGN SECTION

**STRUCTURE**

DRAWN BY	PLANS CK'D.

**82W" PRESTRESSED GIRDER DETAILS** SHEET