

GENERAL NOTES

BID ITEM SHALL BE "FENCE CHAIN LINK -FT" WHICH INCLUDES ALL ITEMS SHOWN.

POSTS ARE TO BE SET VERTICAL.

ALL FENCING COMPONENTS SHALL BE GALVANIZED STEEL OR APPROVED ALTERNATE LISTED BELOW.

ALL RAILS, POSTS AND SLEEVES ARE STANDARD WEIGHT PIPE, SCHEDULE 40.

PLACE ALL NUTS ON OUTSIDE OF FENCE.

TOP RAIL SHALL BE CONTINUOUS OVER INTERIOR POSTS. MINIMUM LENGTH OF TOP RAIL BETWEEN SPLICES SHALL BE 20'-0". PLACE TOP RAIL SPLICES NEAR 1/4 POINTS OF POST SPACING. NO. 9 GAGE TIES AT 9" SPACING REQ'D. ON RAILS & POSTS WITHOUT TENSION BARS.

ALTERNATE FENCING MATERIALS ARE ALUMINUM, ALUMINUM COATED STEEL AND APPROVED COLOR COATING SYSTEMS. IF ALTERNATE MATERIALS ARE USED FOR POSTS & RAILS, THESE ELEMENTS SHOULD BE DESIGNED.

* ALTERNATE BOULEVARD 2-WAY CLAMP MAY BE USED WHEN THE POST IS EITHER BOLTED TO THE 3/2" SLEEVE OR DIRECTLY WELDED TO THE BASE PLATE.

▲ 1/2" DIA. X 6 7/8" LONG GALVANIZED HEX BOLT WITH NUT & WASHER, TYPE S, 1/2" ϕ CONCRETE MASONRY ANCHORS MAY BE SUBSTITUTED FOR 1/2" ϕ BOLTS. ANCHOR PLATE NOT REQUIRED WHEN TYPE S ANCHORS ARE USED. SEE ★

★ 1/2" CONCRETE MASONRY ANCHOR, TYPE "S" 6" MIN. EMBEDMENT (EPOXY ANCHORED MIN. PULLOUT OF 10 KIPS, THREADED LENGTH OF ANCHOR, WASHER, AND NUT SHALL BE GALVANIZED.

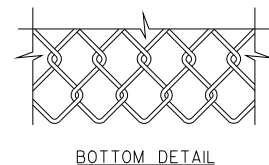
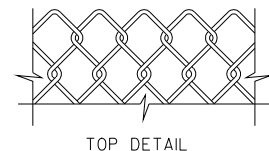

FENCE FABRIC

FENCE FABRIC WOVEN OF 9-GAUGE WIRE IN 2" DIAMOND PATTERN MESH WITH BOTH THE TOP AND BOTTOM SELVAGES KNUCKLED.

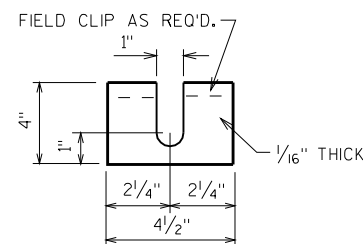

POST SHIM DETAILS

SHIMS REQUIRED ONLY WHEN POSTS ARE WELDED TO BASE PLATES. PROVIDE 4 SHIMS PER POST.

FENCE PART ELEVATION

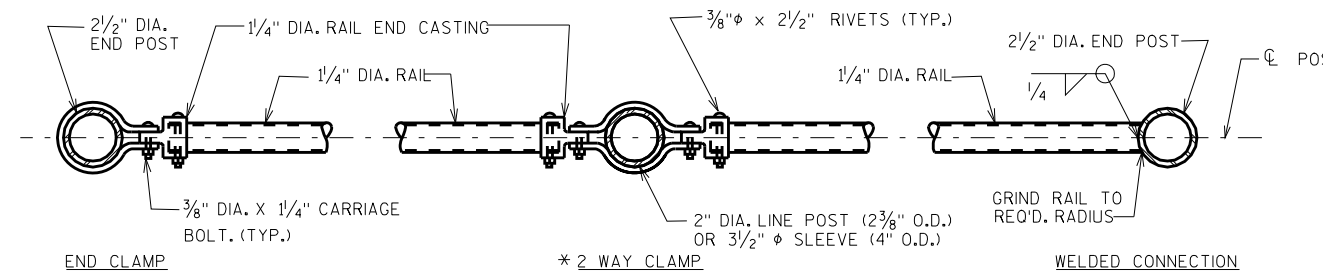

SECTION A-A

NOTE: PLACE ALL NUTS ON OUTSIDE OF FENCE USE HARDWARE AS DETAILED

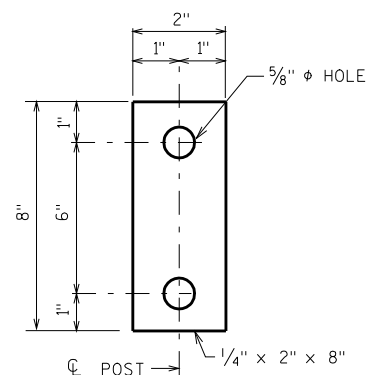

ANCHOR PLATE

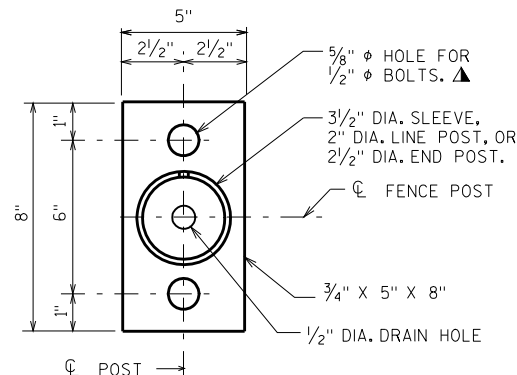

BASE PLATE

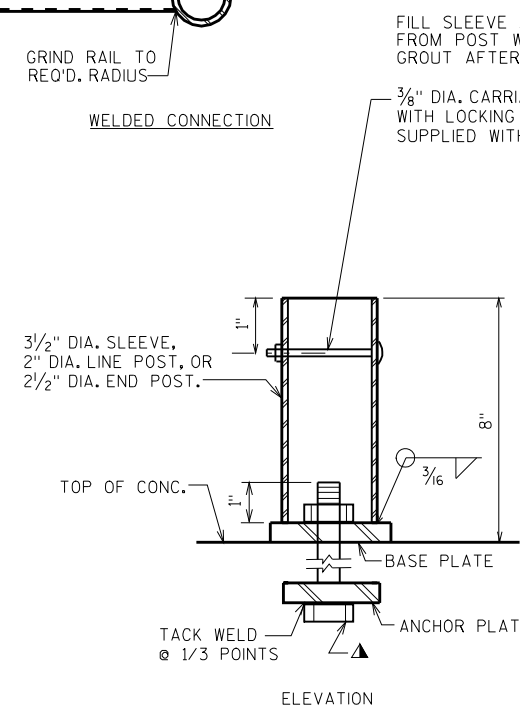

POST ATTACHMENT

UNIT SHALL BE GALV. AFTER FABRICATION

NOTE: IN LIEU OF USING THE 3/2" ϕ SLEEVE, THE 2" ϕ FENCE POST MAY BE WELDED TO THE BASE PLATE.

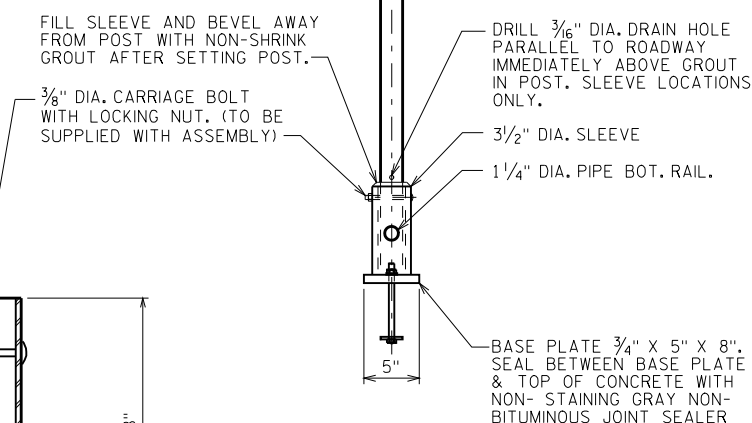

DETAIL A

NO.	DATE	REVISION	BY
STATE OF WISCONSIN DEPARTMENT OF TRANSPORTATION STRUCTURES DESIGN SECTION			
STRUCTURE			
DRAWN BY		PLANS CK'D.	
FENCING DETAILS			SHEET

8

8

SECTION THRU FENCE

SCALE = 5:33333