

LEGEND

- (1A) PLATE 5/8" X 6" X 8" WITH 3/4" X 1/2" SLOTTED HOLES.
- (1C) PLATE 5/8" X 8" X 1'-1" WITH 3/4" X 1/2" SLOTTED HOLES.
- (2A) 1/4" X 5" X 7" ANCHOR PLATE WITH 1/16" φ HOLES FOR ANCHOR BOLTS NO. 3.
- (2C) 1/4" X 2 1/2" X 7 1/4" ANCHOR PLATE WITH 1/16" φ HOLES FOR ANCHOR BOLTS NO. 3.
- (3) 5/8" DIA. X 7 1/2" LONG ASTM F593 TYPE 316 STAINLESS STEEL ANCHOR BOLTS WITH NUT AND WASHERS OF SAME ALLOY GROUP. (ALTERNATE RAIL POST ANCHORAGE - 4 EQUIV. STAINLESS STEEL CONCRETE MASONRY ANCHORS, TYPE S (EPOXY), 5/8" φ, MINIMUM PULLOUT CAPACITY OF 15 KIPS. EMBED A MIN. OF 7" FOR RAIL POSTS AND 5" FOR END RAILS.)
- (4A) STRUCTURAL TUBING 3" X 1 1/2" X 3/16". PLACE VERTICAL. WELD TO NO. 1 & 5.
- (5A) STRUCTURAL TUBING 3" X 1 1/2" X 3/16" RAILS. WELD TO NO. 1 & NO. 4.
- (6B) STRUCTURAL TUBING 1" X 1/2" X 1/8" PICKETS. WELD TO NO. 5. PLACE VERTICAL.
- (6C) STRUCTURAL TUBING 1" X 1/2" X 1/8" PICKETS. WELD TO NO. 11. PLACE VERTICAL.
- (8) 5" φ SCH. 40 PIPE (5 5/16" O.D.) 1/2" LONG SLICES. WELD TO NO. 5A.
- (9A) RECTANGULAR SLEEVE FABRICATED FROM 3/16" PLATES. PROVIDE "SLIDING FIT".
- (10A) RECTANGULAR SLEEVE FABRICATED FROM 3/16" PLATES. (1'-4" @ FIELD ERECTION JTS.) (1'-4" @ STRIP SEAL EXP. JTS.)
- (11A) BAR 2 1/2" X 1" X " - ".
- (12) 1/2" DIA. STAINLESS STEEL BOLT WITH NUT AND LOCKWASHER.

NOTES

BID ITEM SHALL BE "RAILING STEEL TYPE C1 B--", WHICH SHALL INCLUDE ALL STEEL ITEMS SHOWN, AND PAINTING.

POST BASE PLATES SHALL BE FLAT WITH ALL SURFACES SMOOTH AND FREE FROM WARP AND ALL EDGES SMOOTH, STRAIGHT AND VERTICAL. ALL PLATE CUTS SHALL BE MACHINE OR MACHINE FLAME CUTS.

NO. 1, 2, 8, 9 AND NO. 10 SHALL CONFORM TO THE REQUIREMENTS OF ASTM A709 GRADE 36. STRUCTURAL TUBING SHALL CONFORM TO THE REQUIREMENTS OF ASTM A500 GRADE B (NO. 4, NO. 5, AND NO. 6).

ANCHORAGES SHALL BE ACCURATELY PLACED TO PROVIDE CORRECT ALIGNMENT OF RAILING. SET NORMAL TO GRADE.

CUT BOTTOM OF POST TO MAKE POST VERTICAL IN BOTH TRANSVERSE AND LONGITUDINAL DIRECTION.

STEEL SHIMS SHALL BE PROVIDED & USED UNDER BASE PLATES WHERE REQUIRED FOR ALIGNMENT.

FILL BOLT SLOT OPENINGS IN SHIMS AND PLATE NO. 1 AND CAULK AROUND PERIMETER OF PLATE NO. 1 WITH NON-STAINING GRAY NON-BITUMINOUS JOINT SEALER.

ALL JOINTS AND RECESSES IN CONCRETE PARAPET ARE TO BE VERTICAL.

AFTER FABRICATION, ALL MATERIAL, EXCEPT ANCHORAGE (NO. 2 & 3) & SHIMS SHALL BE PAINTED WITH A THREE COAT ZINC-RICH EPOXY SYSTEM PER WISDOT STANDARD SPECIFICATION, SECTION 517, EPOXY SYSTEM. SHIMS SHALL BE GIVEN ONE COAT OF ZINC RICH PRIMER PAINT. THE FINISH COLOR SHALL BE FEDERAL COLOR NO. . . .

1/4" φ VENT HOLES LOCATED IN TOP RAIL OVER RAIL POSTS AND AT LOW END OF OTHER RAILS.

RAILING SHALL BE FABRICATED IN LENGTHS THAT INCLUDE 3 OR 4 POSTS.

TOUCH-UP PAINTING TO BE DONE AT COMPLETION OF STEEL RAILING INSTALLATION TO THE SATISFACTION OF THE ENGINEER AT NO EXTRA COST.

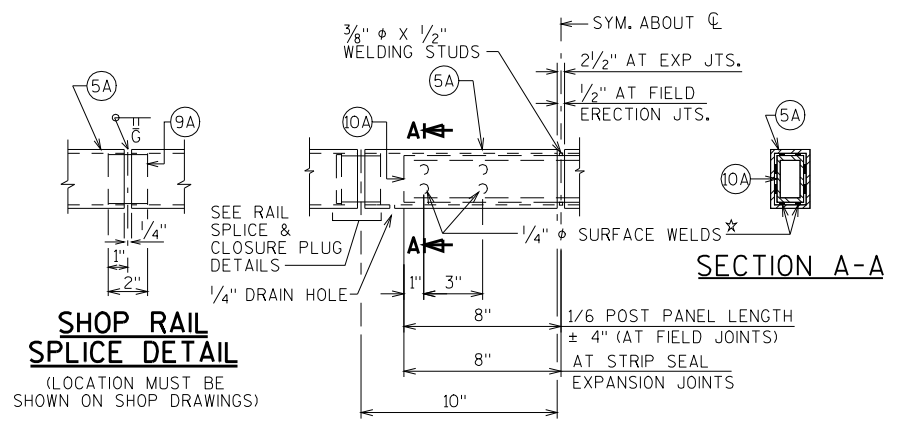
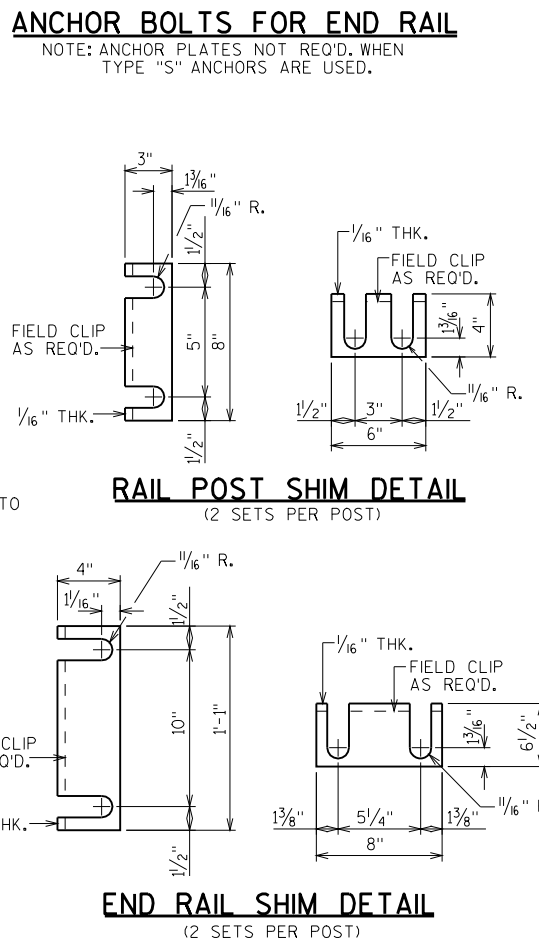
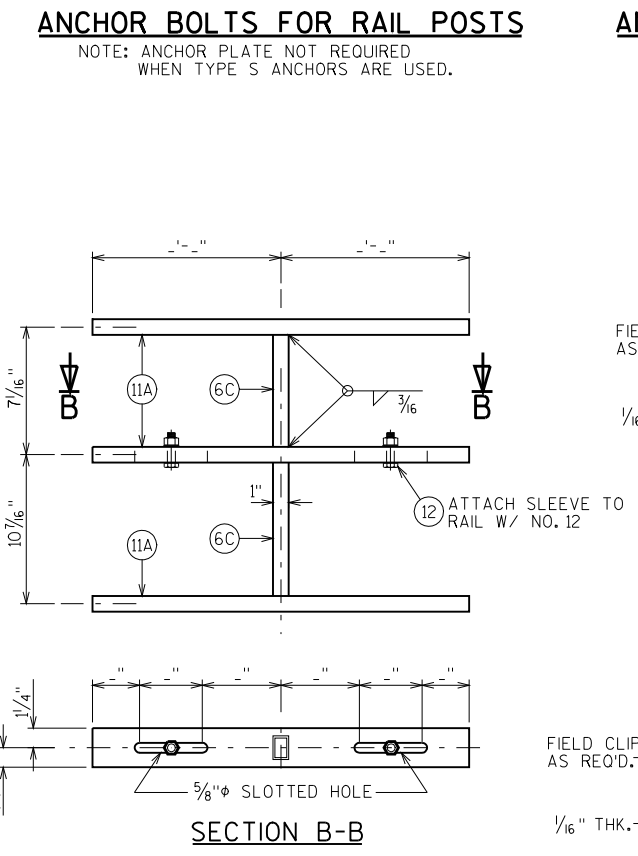
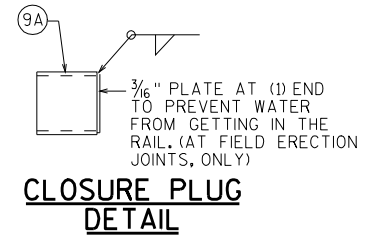
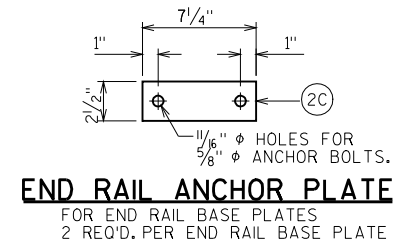
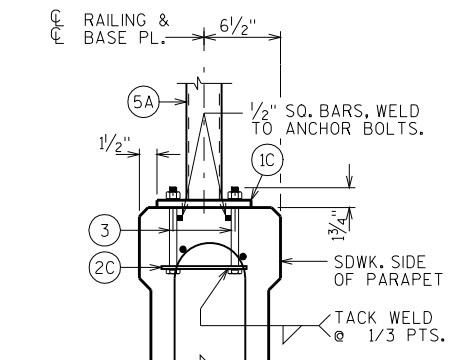
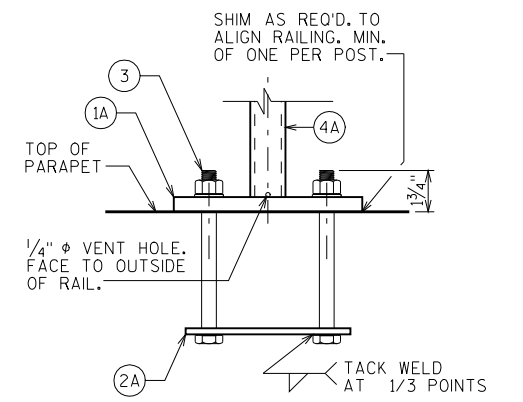
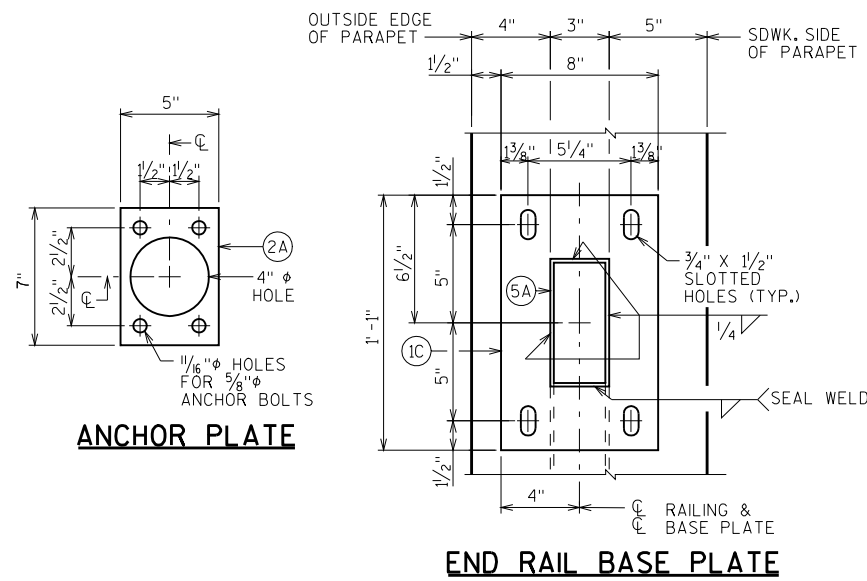
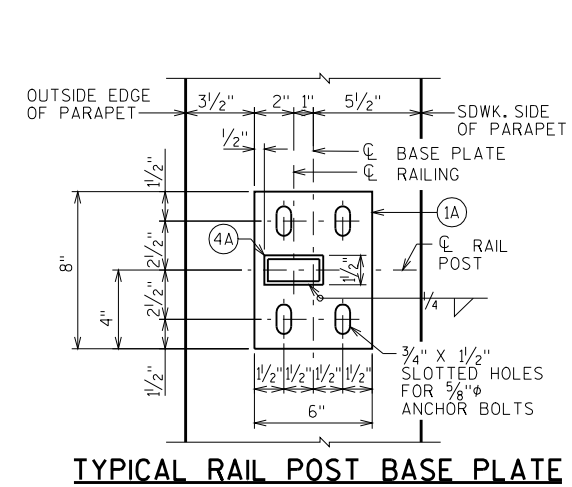

BILL OF BARS

BAR MARK	COAT	ABUT.	ABUT.	LENGTH	BENT	LOCATION
R501	X			6-10	X	PARAPET VERT.
R402	X			-		PARAPET HORIZ.
R503	X			8-2	X	PARAPET VERT. @ WINGS
R404	X			-		PARAPET HORIZ. @ WINGS

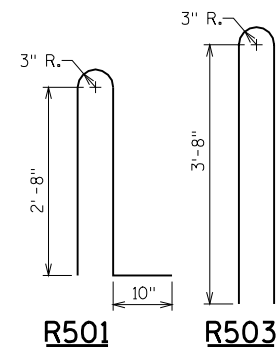

NO.	DATE	REVISION	BY
STATE OF WISCONSIN DEPARTMENT OF TRANSPORTATION STRUCTURES DESIGN SECTION			
STRUCTURE			
DRAWN BY		PLANS CK'D.	
COMBINATION RAIL TYPE "C1"			SHEET