

SECTION A-A

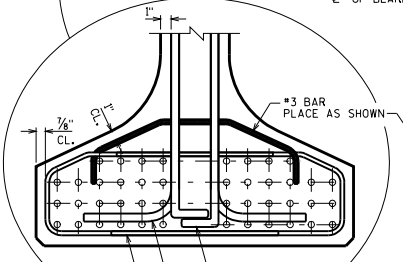

SUPPORT WITH STEEL OR ELASTOMERIC BRGS.

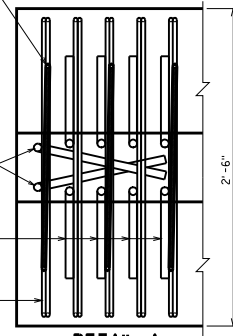

**DETAIL A
BOTTOM FLANGE**

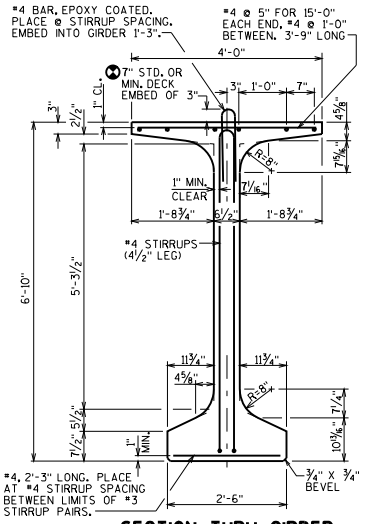

**SECTION THRU GIRDER
STRANDS NOT SHOWN**

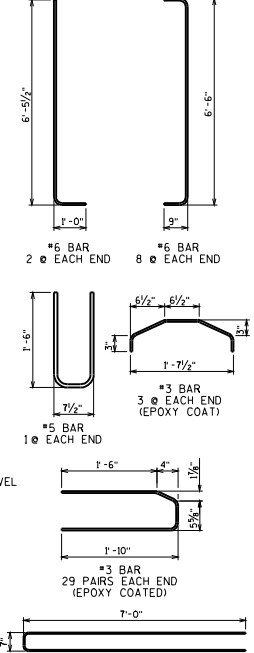

**SECTION THRU GIRDER
SHOWING WELDED WIRE FABRIC (WWF) STIRRUPS**

GENERAL NOTES

THE GIRDERS SHALL BE PROVIDED WITH A SUITABLE LIFTING DEVICE FOR HANDLING AND ERECTING THE GIRDERS.

ALL GIRDERS SHALL BE CAST FULL LENGTH AS SHOWN.

STRANDS SHALL BE FLUSH WITH END OF GIRDER. FOR GIRDER ENDS EMBEDDED COMPLETELY IN CONCRETE, ENDS OF STRANDS SHALL BE COATED WITH NON-BITUMINOUS JOINT SEALER. FOR GIRDER ENDS THAT ARE FINALLY EXPOSED, COAT THE GIRDER ENDS, EXPOSED STRAND ENDS AND ALL NON-BONDING SURFACES WITHIN 2 FEET OF THE GIRDER ENDS WITH A NON-PIGMENTED EPOXY CONFORMING TO AASHTO M-235 TYPE III, GRADE 2, CLASS B OR C. THE EPOXY SHALL BE APPLIED AT LEAST 3 DAYS AFTER MOIST CURING HAS CEASED AND PRIOR TO THE APPLICATION OF THE JOINT SEALER.

DO NOT APPLY CONCRETE SEALER TO SURFACES RECEIVING APPLICATION OF CONCRETE STAINING.

TOP OF GIRDER TO BE ROUGH FLOATED AND BROOMED TRANSVERSELY FOR BONDING TO THE SLAB, EXCEPT THE OUTSIDE 15" OF GIRDER, WHICH SHALL RECEIVE A SMOOTH FINISH. AN APPROVED CONCRETE SEALER SHALL BE APPLIED TO ALL SMOOTH SURFACES INCLUDING THE OUTSIDE 15" OF THE TOP FLANGE.

SPACING SHOWN FOR #4 STIRRUPS IS FOR GRADE 60 REINFORCEMENT. IF THE FABRICATOR WANTS TO BUILD A BAR STEEL CAGE BY WELDING LONGITUDINAL REINFORCEMENT TO THE #4 STIRRUPS, THE FOLLOWING OPTION IS AVAILABLE:

USE ASTM A706, GRADE 60 REINFORCEMENT AND THE STIRRUP SPACING AS SHOWN ON THE PLANS.

AN ALTERNATE EQUIVALENT OF WELDED WIRE FABRIC (WWF) ASTM A497 MAY BE SUBSTITUTED FOR THE STIRRUP REINFORCEMENT SHOWN UPON APPROVAL OF THE STRUCTURES DEVELOPMENT CHIEF, 6081266-5161.

DESIGNER NOTES

BID ITEM SHALL BE "PRESTRESSED GIRDER TYPE 1 82W-INCH".

SPECIFY CONCRETE STRENGTH AS REQUIRED BY DESIGN FROM A MINIMUM OF 6,000 PSI TO A MAX. OF 8,000 PSI. MAXIMUM RELEASE STRENGTH IS 6800 PSI. USE 0.6" STRAND FOR ALL PATTERNS. THE MAX. NUMBER OF DRAPED 0.6" STRANDS IS 6.

REINFORCEMENT IN STANDARD END SECTION OF THE GIRDER IS BASED ON THE STRAND PATTERNS LISTED ON STANDARD 19.20 AND THE SPAN LENGTHS SHOWN IN TABLE 19.3-2. USING DIFFERENT STRAND PATTERNS OR LONGER SPANS WILL REQUIRE A COMPLETE DESIGN OF THIS REINFORCEMENT. PRIOR APPROVAL FROM THE BUREAU OF STRUCTURES IS REQUIRED IF DESIGN OF THE END REINFORCEMENT IS REQUIRED.

- ▲ VARIES FOR ELASTOMERIC BRGS. (STD. 27.07) AND STEEL BRGS (STD. 27.09)
- ⊙ DETAIL TYPICAL AT EACH END
- Ⓢ THE DESIGN ENGINEER NEEDS TO DETERMINE THIS VALUE BASED ON 2" MIN. HAUNCH AT EDGE OF GIRDER, X-SLOPE, PROFILE GRADE LINE AND RESIDUAL CAMBER OF THE GIRDER, INCLUDING VARIANCE IN GIRDER CAMBER OF 3/4". THIS VALUE CAN VARY AND SHOULD BE GIVEN FOR EACH 1/3 OF GIRDER LENGTH. ONE VALUE FOR ENTIRE GIRDER LENGTH CAN BE GIVEN IF 3" MIN. DECK EMBEDMENT AND 2 1/2" CLEAR FROM TOP OF DECK.

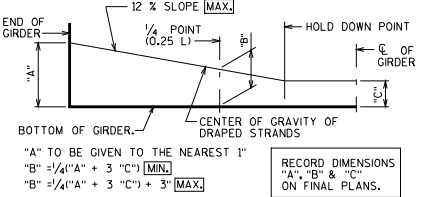

LOCATION OF DRAPED STRANDS

THERE IS CURRENTLY A MORATORIUM ON THE USE OF 82W" PRESTRESSED GIRDERS.

82W" PRESTRESSED GIRDER DETAILS	
STATE OF WISCONSIN DEPARTMENT OF TRANSPORTATION STRUCTURES DEVELOPMENT SECTION	
APPROVED: Scot Becker	DATE: 7-09