

- * "A" = PRESTRESS CAMBER
- * "B" = DEAD LOAD DEFLECTION * ROUND OFF TO NEAREST 1/4"
- * "C" = RESIDUAL CAMBER

DESIGNER NOTES

- 1 PRESENT PRACTICE IS TO USE A MINIMUM "HAUNCH HEIGHT" (AT EDGE OF GIRDER FLANGE) OF 2" FOR DESIGN CALCULATIONS. THE MINIMUM HAUNCH (AT EDGE OF GIRDER FLANGE) ALLOWED IN CONSTRUCTION IS 1/4".
- USE THE CALCULATED THEORETICAL AVERAGE "HAUNCH HEIGHT" AT CENTERLINE OF FLANGE FOR COMPUTING THE HAUNCH CONCRETE QUANTITY.
- USE TOP OF DECK ELEVATIONS AND CALCULATED "HAUNCH HEIGHT" AT CENTERLINE OF GIRDER FOR COMPUTING BEAM SEAT ELEVATIONS AT SUBSTRUCTURES.
- "INTERMEDIATE CONCRETE DIAPHRAGMS" SHALL BE USED ONLY WHEN THE USE OF STEEL DIAPHRAGMS IS NOT FEASIBLE BECAUSE OF UTILITIES OR FOR OTHER SPECIAL SITUATIONS. ONLY ONE TYPE OF INTERMEDIATE DIAPHRAGM SHALL BE SHOWN ON THE PLANS. THE USE OF BOTH INTERMEDIATE CONCRETE & STEEL DIAPHRAGMS ON THE SAME BRIDGE IS NOT ALLOWED.
- FOR SKEWS < 10°, PLACE INTERMEDIATE DIAPHRAGMS IN A STRAIGHT LINE. REFER TO STANDARD 19.36. PROVIDE OFFSET FOR SKEWS > 10°.
- PIER PILASTERS ARE TYPICALLY NOT USED, BUT MAY BE USED AS PART OF THE BRIDGE AESTHETIC PACKAGE ON 28", 36", 45", 54" AND 70" PRESTRESSED GIRDERS. PILASTERS ARE NOT USED ON 45W", 54W", 72W" OR 82W".
- WHEN THE TYPE "M" RAILING IS USED WITH THE 28", 36", 45", 54W", 54" AND 70", THE THICKNESS AT THE EDGE OF DECK IS 10/2".

DIAPHRAGM SPACING: FOR SPANS < 80'-0" PLACE ONE DIAPHRAGM AT MID-LENGTH OF GIRDER, FOR SPANS OVER 80'-0" PLACE AT 1/3 AND 2/3 POINTS.

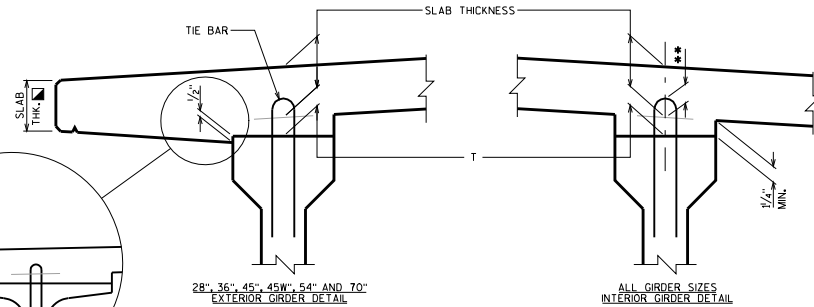

SLOPE BTM OF SLAB @ EXTERIOR GIRDER TO MATCH THE SLOPE OF THE BTM OF TOP FLANGE

54W", 72W" & 82W" EXTERIOR GIRDER DETAIL

IF 1/4" MINIMUM HAUNCH HEIGHT AT EDGE OF GIRDER CANNOT BE MAINTAINED, THE GRADE LINE MAY BE REVISED BY THE ENGINEER AT THE OPTION OF THE CONTRACTOR, THE PLAN SLAB THICKNESS SHALL BE HELD, NOTIFY THE STRUCTURES SECTION IF THE GRADE LINE IS RAISED FROM THE PLAN PROFILE BY MORE THAN 1/2" OR, ** IF 3" MINIMUM DECK EMBEDMENT OF TIE BAR CANNOT BE OBTAINED, TO DETERMINE 'T', ELEV. OF TOP OF GIRDS. AT CL OF SUBSTRUCTURE UNITS & AT 1/10 POINTS OF EACH SPAN SHALL BE TAKEN, THEN FOLLOW THIS PROCESS:

- TOP OF DECK ELEV. AT FINAL GRADE
- TOP OF GIRDER ELEVATION
- + DEAD LOAD DEFLECTION
- = SLAB THICKNESS
- = HAUNCH HEIGHT 'T'

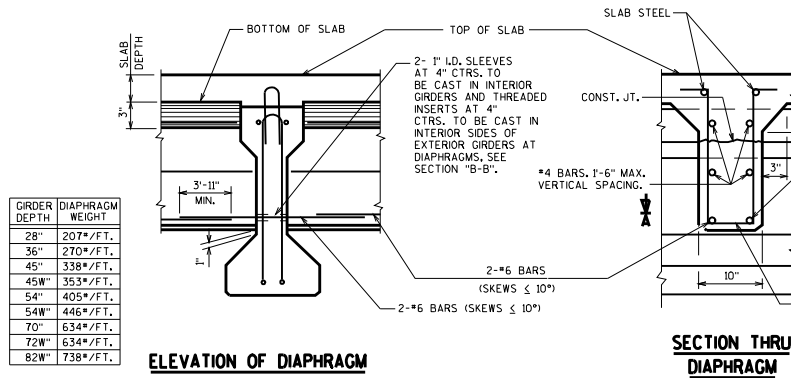
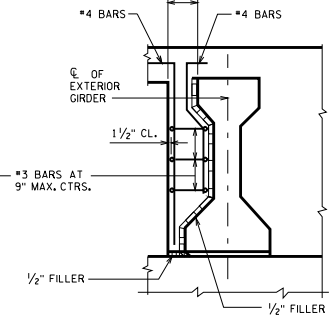
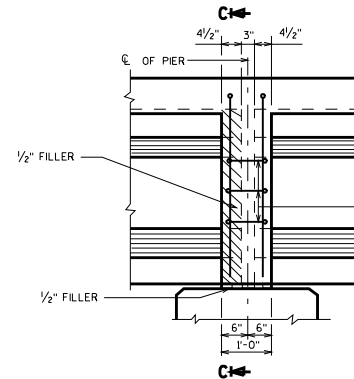

GIRDER DEPTH	DIAPHRAGM WEIGHT
28"	207#/FT.
36"	270#/FT.
45"	338#/FT.
45W"	353#/FT.
54"	405#/FT.
54W"	446#/FT.
70"	634#/FT.
72W"	634#/FT.
82W"	738#/FT.

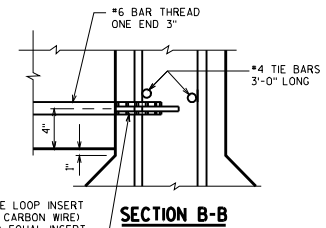
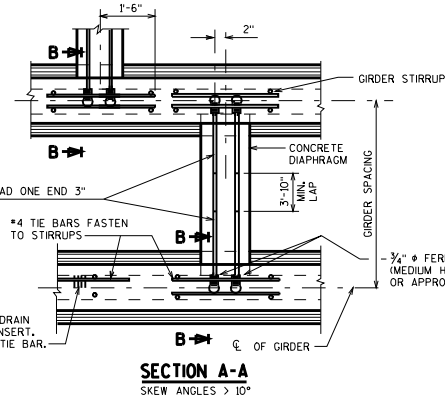

PRESTRESSED GIRDER DETAILS

STATE OF WISCONSIN
DEPARTMENT OF TRANSPORTATION
STRUCTURES DEVELOPMENT SECTION

APPROVED: **Scot Becker**

DATE:
7-08