

**24'-0" & 28'-0" ROADWAY**

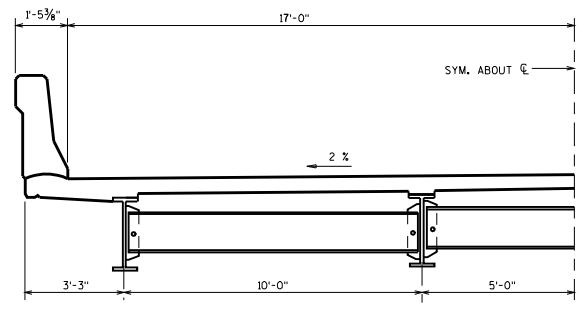

**34'-0" ROADWAY**

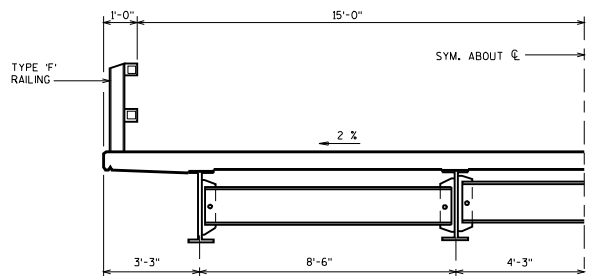

**30'-0" ROADWAY**

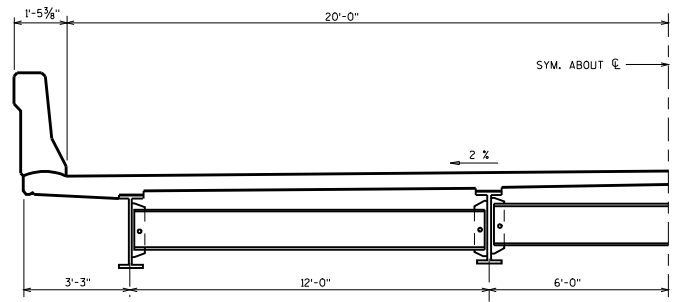

**40'-0" ROADWAY**

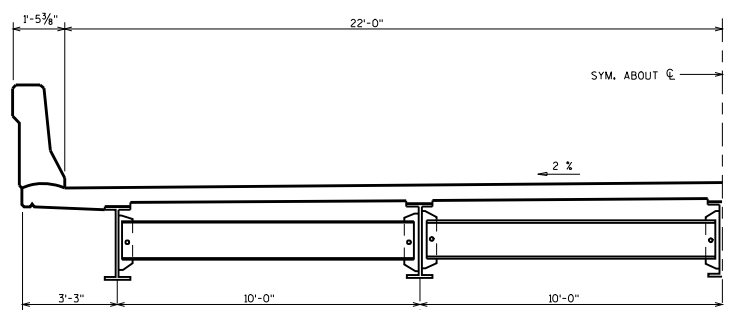

**44'-0" ROADWAY**

**NOTES**  
 GIRDER SPACINGS SHOWN MAY BE MODIFIED BY THE DESIGNER IF OTHER SPACINGS RESULT IN A MORE ECONOMICAL SECTION.  
 SEE CHAPTER 17 IN THE BRIDGE MANUAL FOR DECK THICKNESS.

<b>STEEL GIRDER SUPERSTRUCTURE SECTIONS</b>	
STATE OF WISCONSIN DEPARTMENT OF TRANSPORTATION STRUCTURES DEVELOPMENT SECTION	
APPROVED: <b>Scot Becker</b>	DATE: 7-08